

NOTES:

1. DOVETAIL WIDTH WILL NOT CHANGE WITH VARYING DOVETAIL DEPTH.
2. MACHINE EDGE BREAK ON DOVETAIL POINT.
3. SLOT DIMENSION TO THE CENTERLINE IS **CRITICAL**, IF DIMENSION IS TOO LARGE, STOCK MAY REST AGAINST LOCATING PIN INSTEAD OF DOVETAIL CUT SURFACES.
4. IF STOCK IS OVERSIZE, THIS TOLERANCE INCREASES BY HALF OF THE EXTRA STOCK.

D362 DOVETAIL STOCK PREPARATION

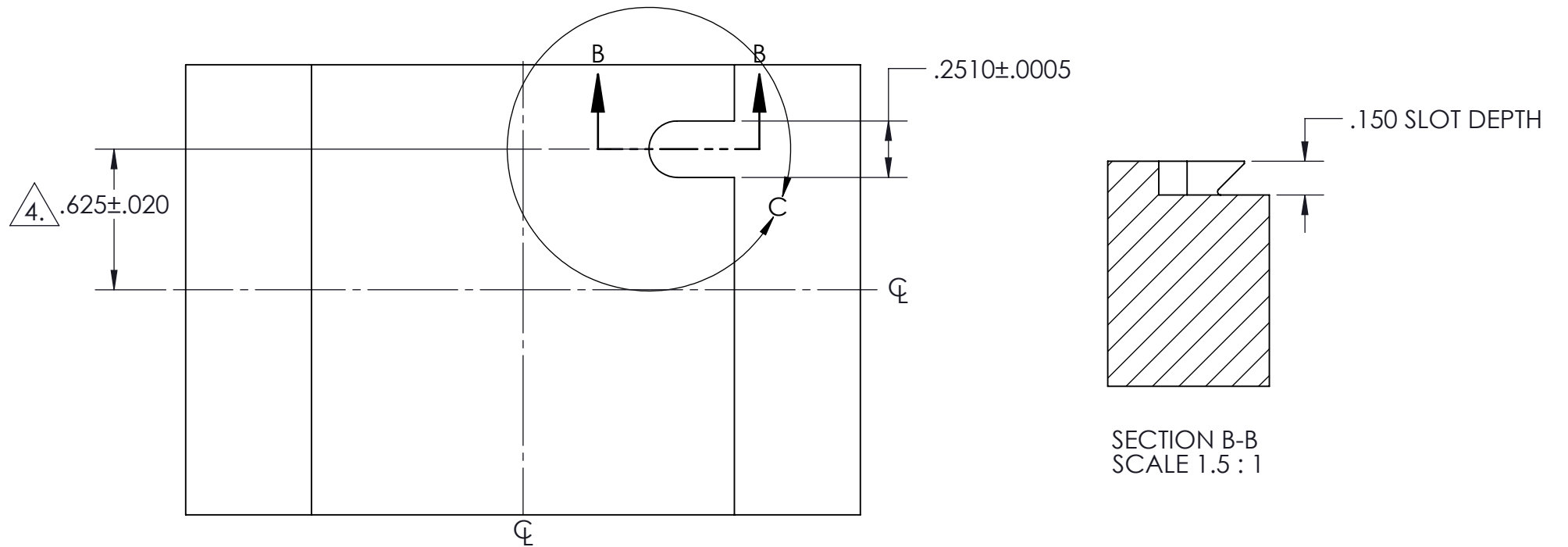
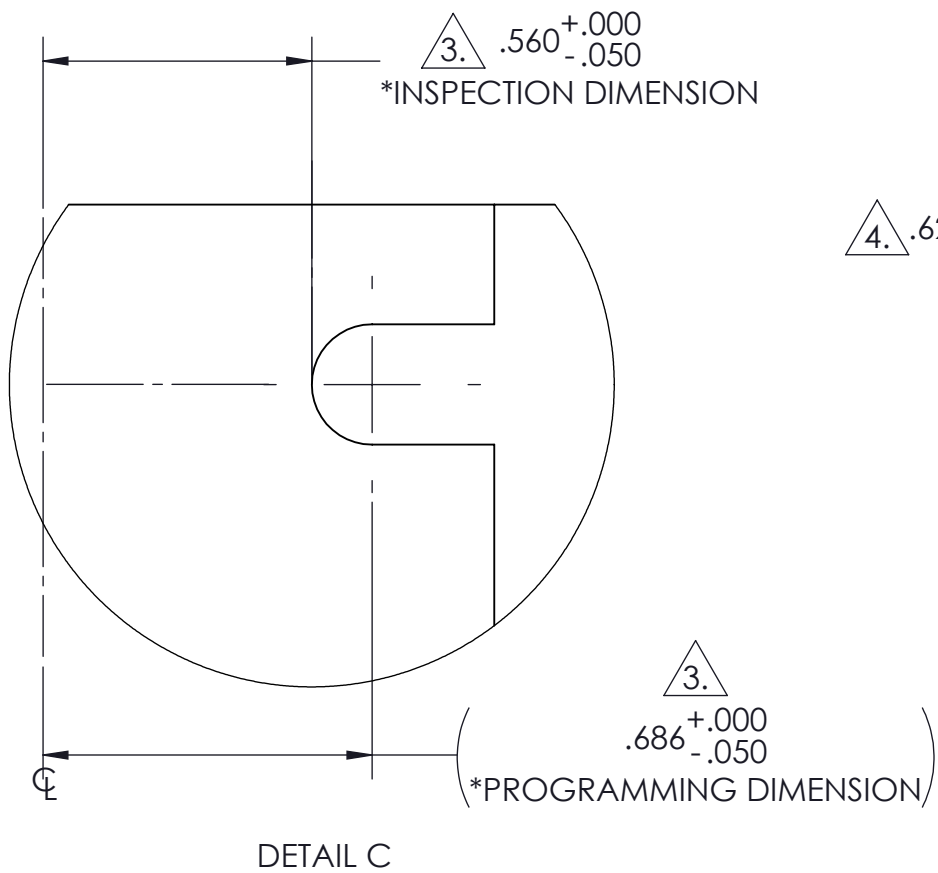
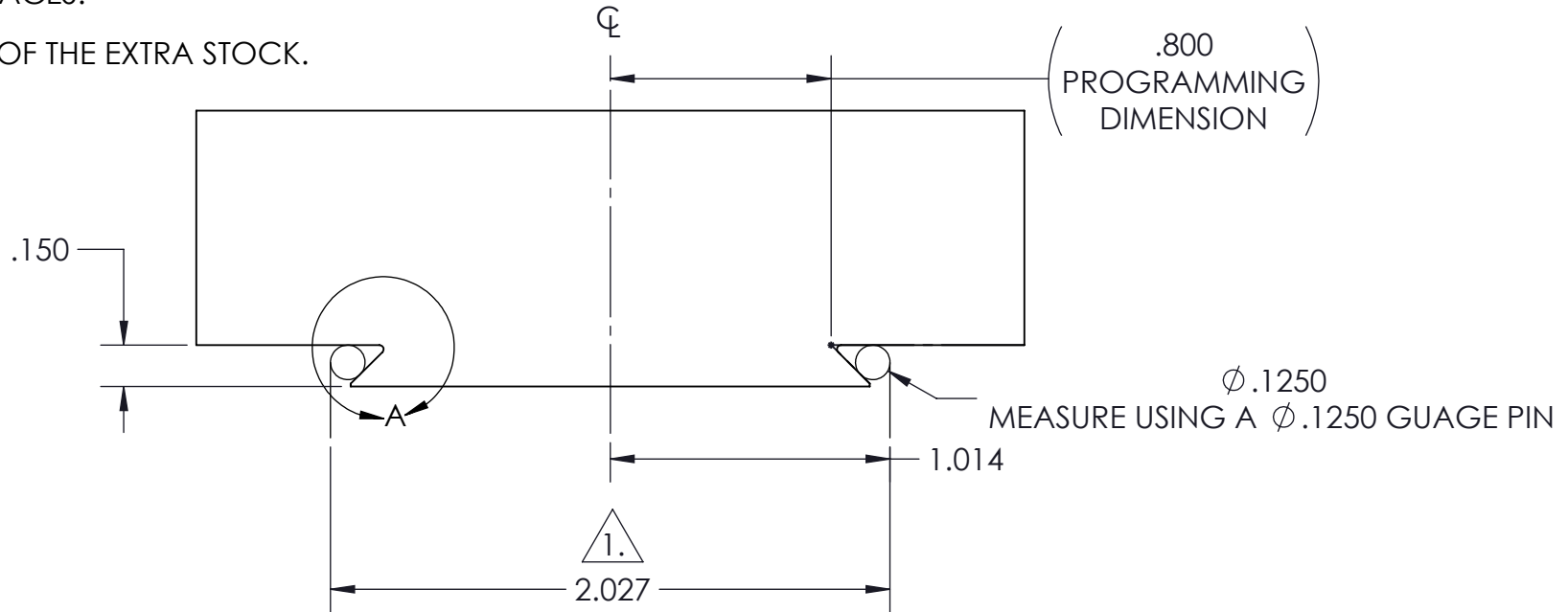
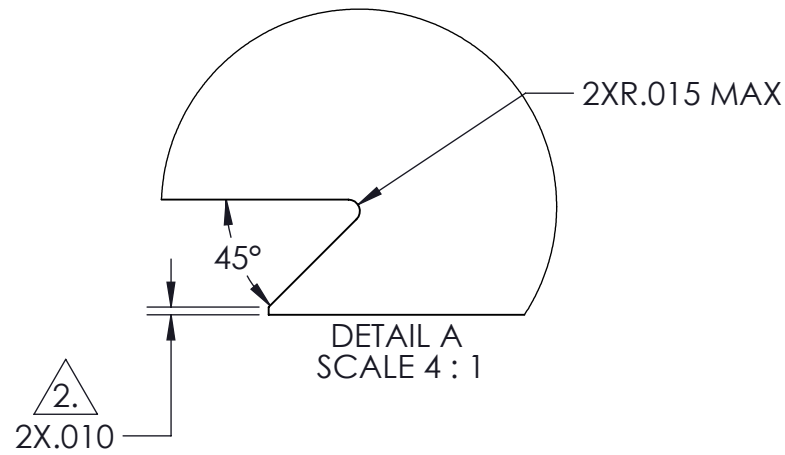

INCH <small>DRAWN IN ACCORDANCE WITH ASME Y14.5-2009</small> PROPRIETARY AND CONFIDENTIAL <small>THE INFORMATION CONTAINED IN THIS DRAWING IS THE SOLE PROPERTY OF FIFTH AXIS, INC. ANY REPRODUCTION IN PART OR AS A WHOLE WITHOUT THE WRITTEN PERMISSION OF FIFTH AXIS, INC. IS PROHIBITED.</small>	TOLERANCES <small>UNLESS OTHERWISE SPECIFIED</small> X ± 0.1 .XX ± 0.01 .X ± 0.05 .XXX ± 0.005 ANGULAR ± 0.5°		<small>WWW.FIFTHAXIS.COM</small> 7140 ENGINEER ROAD SAN DIEGO, CA 92111 P (858) 505-0432 F (858) 505-9344
	<small>THIRD ANGLE PROJECTION</small> 		DESCRIPTION D362 DOVETAIL STOCK PREP
SIZE B	PART NO. DSP-D362	REV A	<small>DO NOT SCALE DRAWING SCALE 1:2 WEIGHT: SHEET 1 OF 1</small>