

NOTES:

- 1. DOVETAIL WIDTH WILL NOT CHANGE WITH VARYING DOVETAIL DEPTH
- 2. MACHINE EDGE BREAK ON DOVETAIL POINT
- 3. SLOT DIMENSION TO THE CENTERLINE IS **CRITICAL**, IF DIMENSION IS TOO LARGE, STOCK MAY REST AGAINST LOCATING PIN INSTEAD OF DOVETAIL CUT SURFACES.
- 4. IF STOCK IS OVERSIZED, THE TOLERANCE IS INCREASED BY HALF THE EXTRA STOCK

DM12 DOVETAIL STOCK PREPARATION

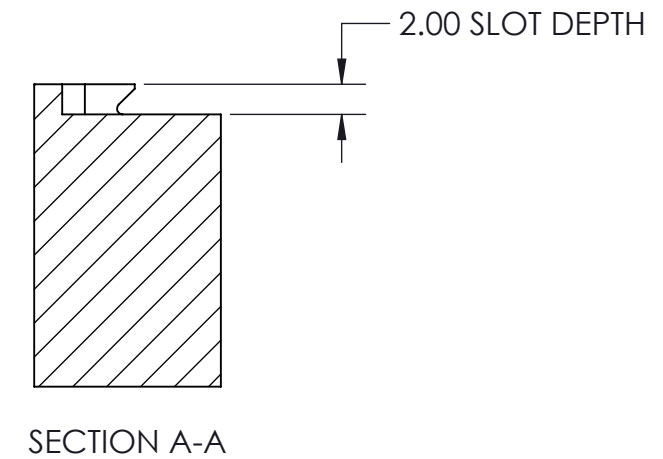
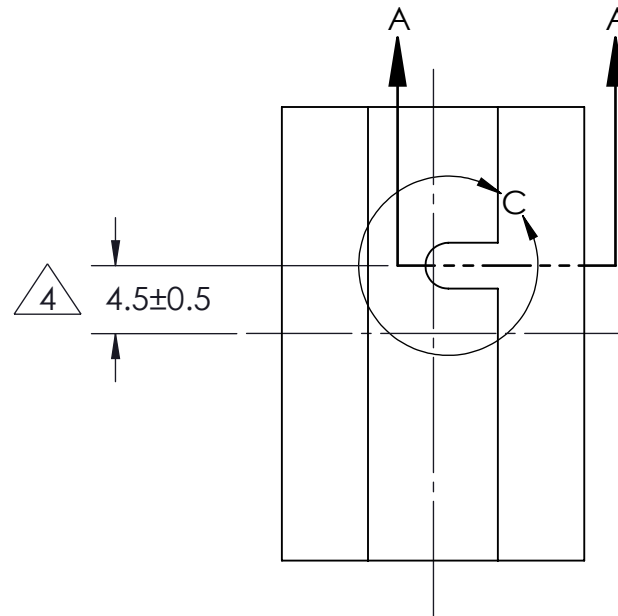
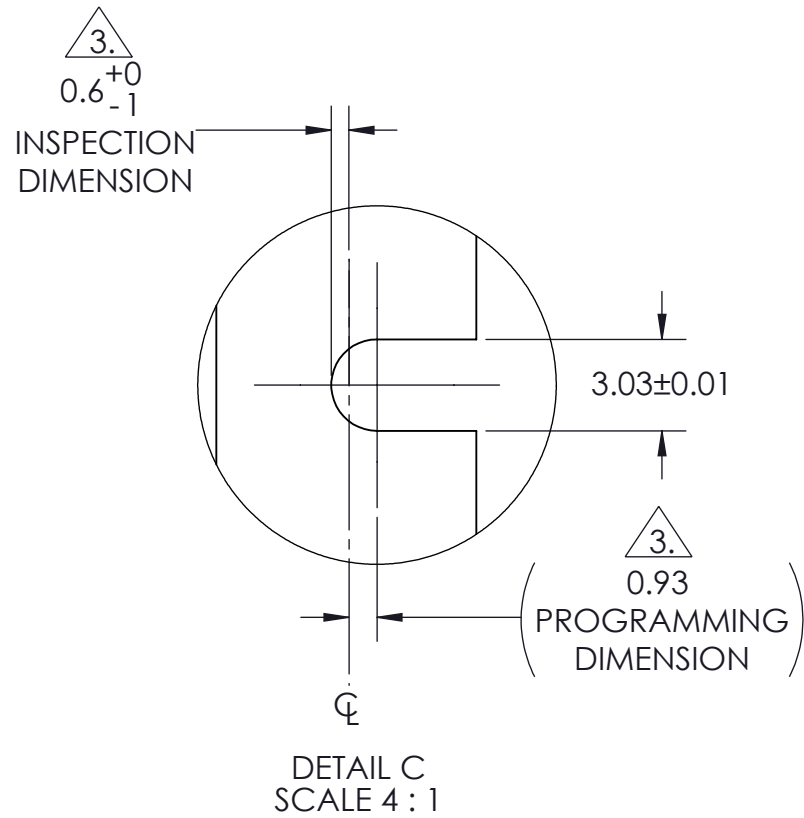
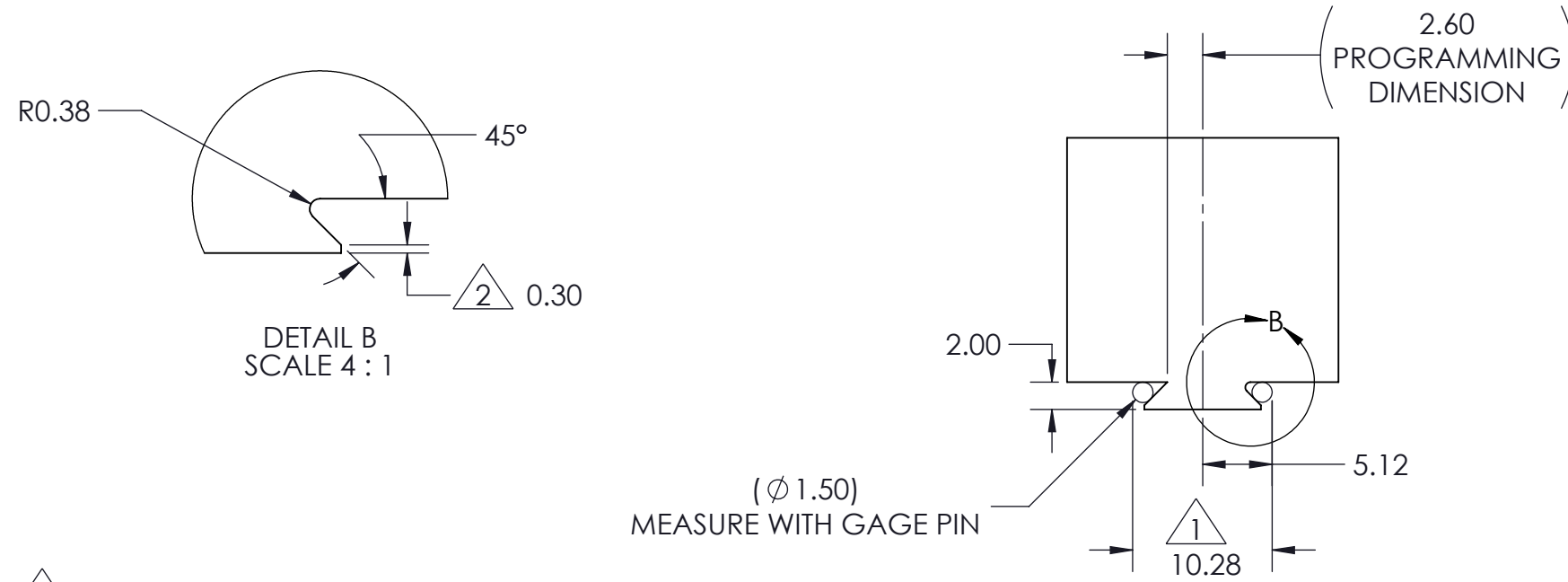

MILLIMETER <small>DRAWN IN ACCORDANCE WITH ASME Y14.5-2009</small> PROPRIETARY AND CONFIDENTIAL <small>THE INFORMATION CONTAINED IN THIS DRAWING IS THE SOLE PROPERTY OF FIFTH AXIS, INC. ANY REPRODUCTION IN PART OR AS A WHOLE WITHOUT THE WRITTEN PERMISSION OF FIFTH AXIS, INC. IS PROHIBITED.</small>	TOLERANCES <small>UNLESS OTHERWISE SPECIFIED</small> X ± 1.0 .X ± 0.3 ANGLULAR ± 0.5° .XX ± 0.13		<small>WWW.FIFTHAXIS.COM</small> 7140 ENGINEER ROAD SAN DIEGO, CA 92111 P (858) 505-0432 F (858) 505-9344
	<small>THIRD ANGLE PROJECTION</small> 		DESCRIPTION DM12 DOVETAIL STOCK PREP
SIZE B	PART NO. DSP-DM12	REV A	<small>DO NOT SCALE DRAWING</small> <small>SCALE 2:1</small> <small>WEIGHT:</small> <small>SHEET 1 OF 1</small>